

BASIC

SEMI AUTOMATIC SHEET TO SHEET LAMINATING/MOUNTING MACHINE



The Lamina semi automatic Basic is a sheet to sheet laminating/mounting machine. It is an entry level machine, that can expand your finishing business for a low investment.

A wide range of ancillary equipment is available to optimise the efficiency of your machine including Automatic Feeders, Stackers, Pressure Belt, Flip-Flop, Pre-Loading Station etc.

**lamina**[®]

BASIC

SEMI AUTOMATIC SHEET TO SHEET LAMINATING/MOUNTING MACHINE

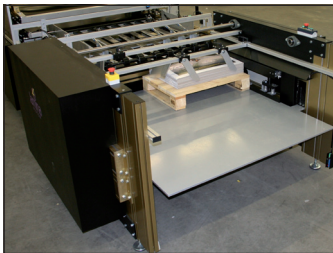
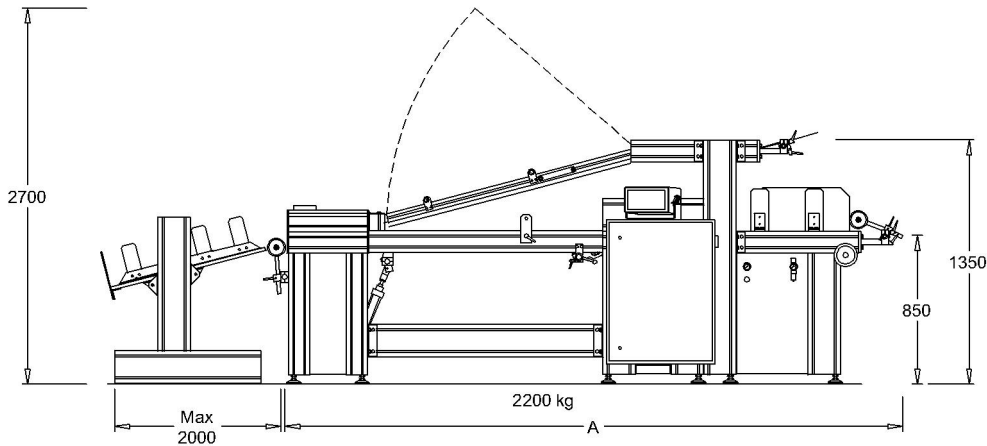

Size Range Model	Maximum Sheet Size		Minimum Sheet Size	
	Width	Length	Width	Length
1116	1100 mm (43")	1600 mm (63")	350 mm (8")	500 mm (20")
1416	1400 mm (55")	1600 mm (63")	350 mm (8")	500 mm (20")
1420	1400 mm (55")	2000 mm (78")	350 mm (8")	500 mm (20")
1620	1600 mm (63")	2000 mm (78")	350 mm (8")	500 mm (20")

Machine Size (incl. Stacking table)

Model	Width	Length A	Weight
1116	2050 mm (81")	5600 mm (220")	2950 kg
1416	2350 mm (92")	5600 mm (220")	3150 kg
1420	2350 mm (92")	6000 mm (236")	3250 kg
1620	2550 mm (100")	6000 mm (236")	3500 kg

Top Sheet	130 to 450 g/m ² 1 pts = 28,25 g/m ²
Bottom Sheet	Thickness: 0,6 to 10 mm (0,016" to 0,39")
Registration Accuracy*	Less than +/- 0,5 mm (0,02")
Total Installed Power	5,0 kW
Electrics	208 V, 3 phase, 60 cycle; or 400 V, 3 phase, 50/60 cycle; or Specify
Air Requirements	6 bar; 80 psi; 34 CFM, Approximately 500 L/min

* Depends on properties of materials being used and existing operating conditions.

Note! For more information and videos, please visit www.laminasystem.com



Head Office, Sweden: Lamina System AB

Vevgatan 21, 504 64 Borås, Sweden, Phone +46 33 23 34 00, Fax +46 33 23 34 10

Web: www.laminasystem.com, e-mail: sales.dept@laminasystem.com