

GLUER

MANUAL FED INLINE FOLDING, GLUING AND TAPING MACHINE

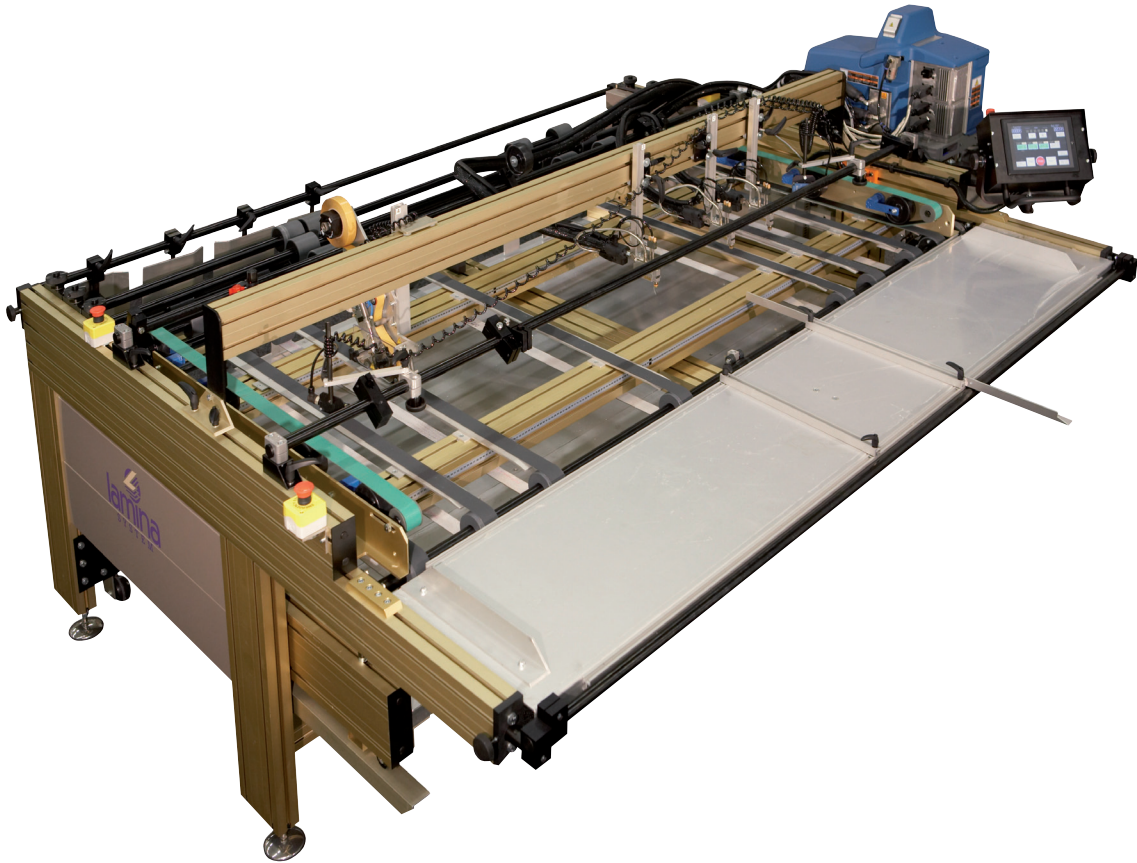

The Lamina Gluer is a manual fed inline folding, gluing and taping machine. By the genius construction it is able to handle various sizes of different materials.

The tool free set-up allows a quick change over even for a short run. Options for the machine include cold glue, back support unit, tape applicator etc.



GLUER

MANUAL FED INLINE FOLDING, GLUING AND TAPING MACHINE

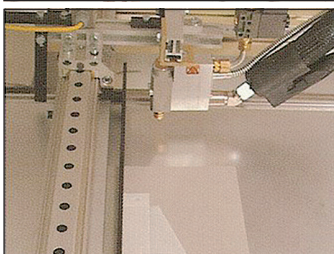
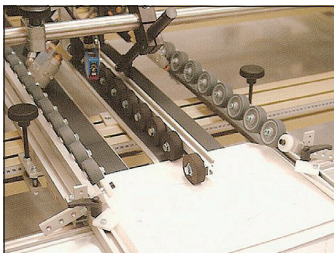
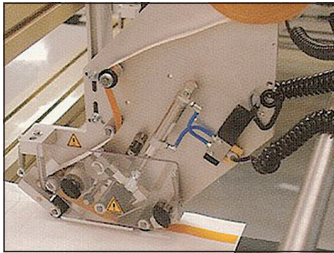
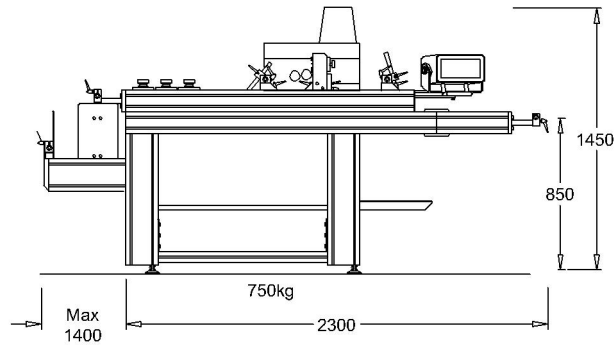

| Size Range Model | Maximum Sheet Size Width | Minimum Sheet Size Width |
|------------------|--------------------------|--------------------------|
| 1400 GL | 1400 mm (55") | 70 mm (3") |
| 1800 GL | 1800 mm (71") | 70 mm (3") |
| 2200 GL | 2200 mm (87") | 70 mm (3") |

| Machine Size (incl. Stacking table) | | | |
|-------------------------------------|----------------|----------------|--------|
| Model | Width | Length A | Weight |
| 1400 GL | 2150 mm (85") | 2550 mm (100") | 750 kg |
| 1800 GL | 2400 mm (94") | 2550 mm (100") | 850 kg |
| 2200 GL | 2800 mm (110") | 2550 mm (100") | 950 kg |

| | |
|-----------------------|---|
| Total Installed Power | 5,0 kW |
| Electrics | 208 V, 3 phase, 60 cycle; or 400 V, 3 phase, neutral, 50/60 cycle; or Specify |
| Air Requirements | 6 bar; 80 psi; 34 CFM, Approximately 50 L/min |

Note! For more information and videos, please visit www.laminasystem.com



Head Office, Sweden: Lamina System AB

Vevgatan 21, 504 64 Borås, Sweden, Phone +46 33 23 34 00, Fax +46 33 23 34 10

Web: www.laminasystem.com, e-mail: sales.dept@laminasystem.com